

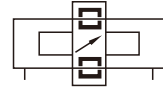

Guided rodless cylinder(Magnetic coupled)——RMT Series

Bore size: $\Phi 16, \Phi 20, \Phi 25, \Phi 32, \Phi 40$



Ordering code

RMT 20×100 S □ T

① ② ③ ④ ⑤ ⑥

① Model

RMT: Guided rodless cylinder
(Magnetic coupled)

② Bore Size

16 20 25 32 40

④ Magnet

Blank: Without magnet

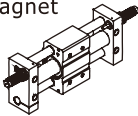

S: With magnet

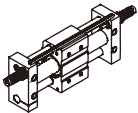

⑥ Thread type [Note2]

T: NPT

③ Stroke [Note1]

Bore size (mm)	Standard stroke (mm)										Max.std stroke	
16	50	100	150	200	250	300	350	400	450	500	750	
20											1000	
25	50	100	150	200	250	300	350	400	450	500	600	1500
32											1500	
40	50	100	150	200	250	300	350	400	450	500	600	1500
	700	750	800	900	1000							

⑤ Cushion type

Blank: With two adjustable nuts

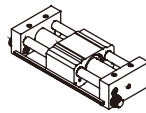

A: With two shock absorbers

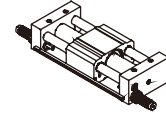

[Note1] Consult us for non-standard stroke.

[Note2] Blank on thread code means metric M thread. There is only metric thread for $\Phi 16$. If NPT thread is needed, please consult.

Specification

Bore size(mm)	16	20	25	32	40
Acting type	Double acting				
Fluid	Air(to be filtered by 40 μ m filter element)				
Operating pressure	30~100psi(0.2~0.7MPa)		36~100psi(0.25~0.7MPa)		
Proof pressure	175psi(1.2MPa)				
Temperature °C	-20~70				
Speed range mm/s	50~400				
Stroke tolerance mm	0~250 ^{+1.0} ₀		251~1000 ^{+1.5} ₀		1001~ ^{+2.0} ₀
Cushion type	Fixed cushion		Shock absorber(Available)		
Safe holding force N	140	220	345	560	880
Port size [Note1]	M5×0.8		1/8"		1/4"

[Note1] NPT thread is available.

Add) Refer to P535 for detail of sensor switch.



RMT Series

Bore size: $\Phi 16$, $\Phi 20$, $\Phi 25$, $\Phi 32$, $\Phi 40$

Product feature

1. This magnetic cylinder is basically a pneumatic rodless cylinder featuring a mobile piston fitted with annular magnets. The mobile carriage is also equipped with magnets to provide magnetic coupling (carriage/piston). The carriage slide freely along the main tube.
2. It is dust-proof as the isolation between the carriage and piston.
3. It is compact in space.
4. The non adjustable rubber bumpers and the adjustable pneumatic cushioning on both ends of the cylinder ensure the smooth action. If shock absorber be used, the cushioning effect is more perfection.
5. Double guides ensure high precision and can endure proper side load or offset load.
6. Non-magnetically conductive materials are recommended for workpieces fitted to the cylinder, otherwise the lifetime may be halved if magnetically conductive materials are used.

Installation and application

1. How to determine load :

1.1) The maxi load to move must be less than the theoretical holding force.

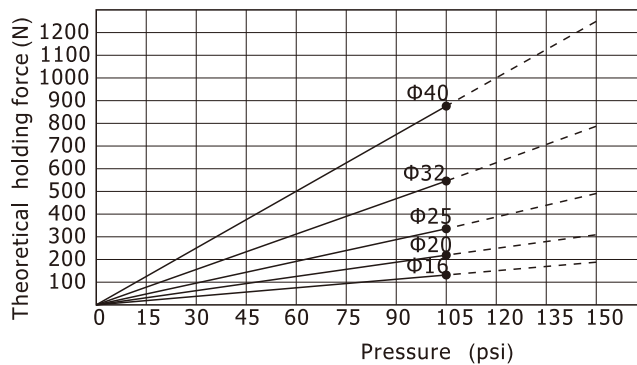

1.2) The relation between loading and stroke as below(Loading center and slide table center must be superposition)

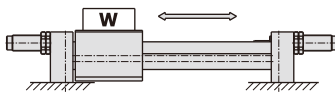

Bore size	Max.Load W(kg)	Stroke scope
16	5.6	~300mm
20	9.6	~500mm
25	16	~500mm
32	24	~600mm
40	40	~600mm

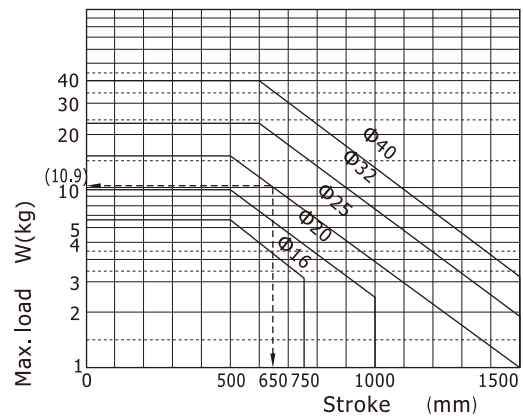

In horizontal movement, please choose proper bore size based on

Load-Velocity chart

A.Find required load

B.Find moving velocity

C.Choose proper spec based on Load-Velocity chart

Load-Velocity chart (Load in horizontal movement and moving velocity)

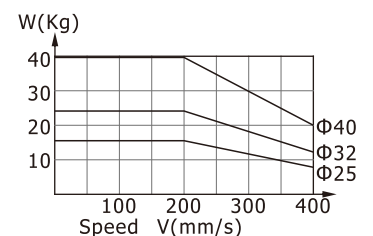
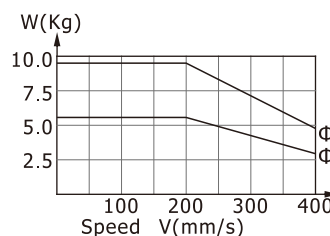

RMT Series

Bore size: $\Phi 16$, $\Phi 20$, $\Phi 25$, $\Phi 32$, $\Phi 40$

1.3. Load-Velocity chart (Load in vertical movement and moving velocity)

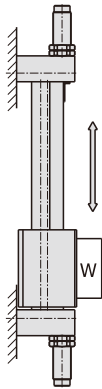

Load-Velocity chart (Load in vertical movement and moving velocity)

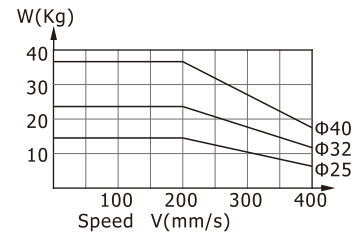
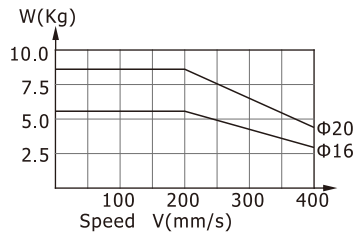

2. About shock absorber

2.1) Shock absorbers are consumable parts. When a decrease in energy absorption capacity is noticed, it must be replaced.

Refer to the table below for shock absorber type.

2.2) Never loosen the bottom screw of the shock absorber. (It is not an adjustment screw.) That may cause oil leakage.

2.3) Refer to the table below for tightening torques of the shock absorber setting nut.

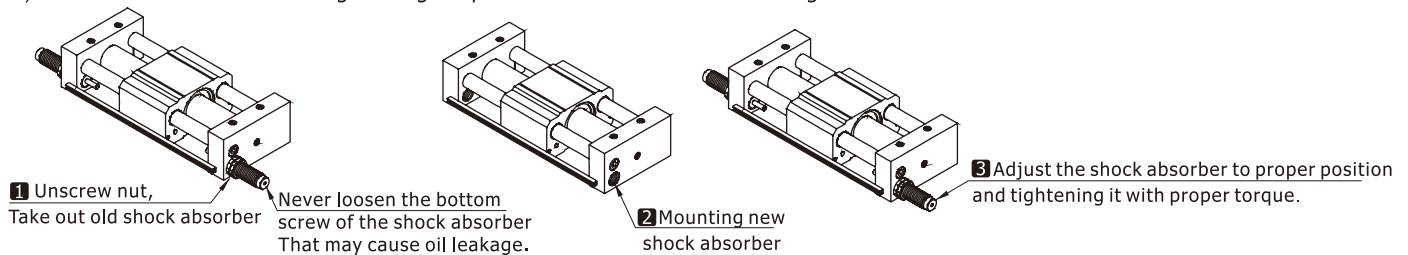

Cylinder model	RMT16	RMT20	RMT25	RMT32	RMT40
Shock absorber type	ACA1006-A	ACA1007-1N	ACA1412-1N	ACA2020-1N	ACA2020-1N
Tightening torque(Nm)	1.67	1.67	3.14	10.80	10.80

3. About sensor switch

3.1) Sensor switch only can be used for the cylinder with magnet . The magnet located the four corner of body's(refer below) .

The cylinder with magnet have both group mounting hole for mounting rail. please refer to below for ordering sensor switch, mounting it into the rsil's groove, adjusting it to proper position, tightening it with proper torque.

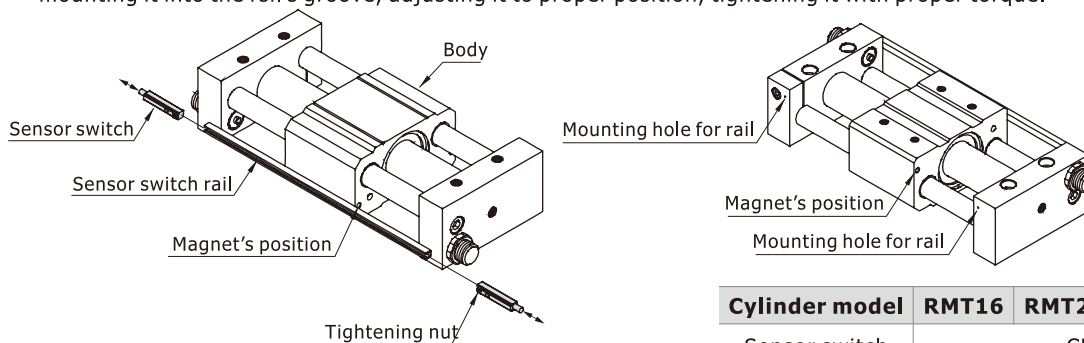

Cylinder model	RMT16	RMT20	RMT25	RMT32	RMT40
Sensor switch	CMSG/DMSG/EMSG				

Guided rodless cylinder(Magnetic coupled)

RMT Series

Bore size: $\Phi 16, \Phi 20, \Phi 25, \Phi 32, \Phi 40$

Inner structure

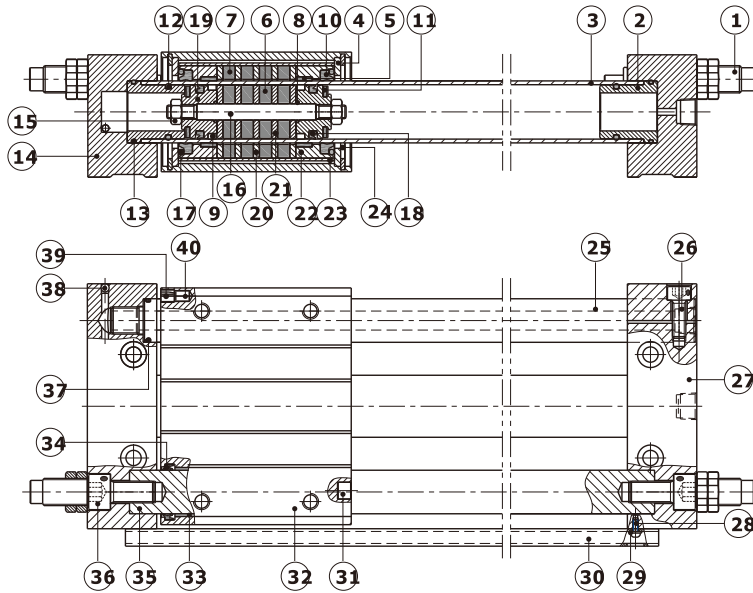

NO.	Item	NO.	Item
1	Shock absorber	21	Magnet washer
2	Washer cover	22	End cover
3	Stainless steel barrel	23	Moveable core
4	Washer	24	C clip
5	Wearing ring	25	Guide I
6	Magnet	26	Countersink screw
7	Magnet	27	Fixing plate
8	O-ring	28	Screw
9	Wear ring	29	Spring washer
10	Scraping dust ring	30	Rail
11	Bumper	31	Bumper block
12	O-ring	32	Barrel
13	O-ring	33	Bushing
14	Fixing plate	34	Gasket
15	Nut	35	Guide II
16	Joint pole	36	Countersink screw
17	O-ring	37	O-ring
18	Piston seal	38	Steel ball
19	Magnet	39	Location washer
20	Magnet washer	40	Magnet

Dimensions

RMT-A

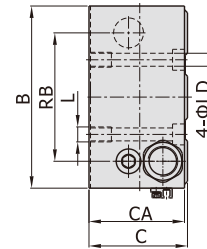
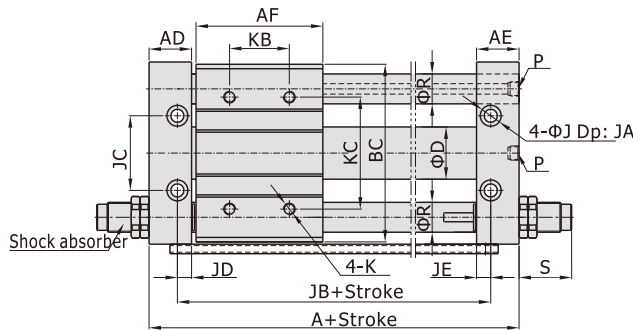

RMT

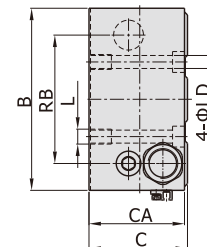
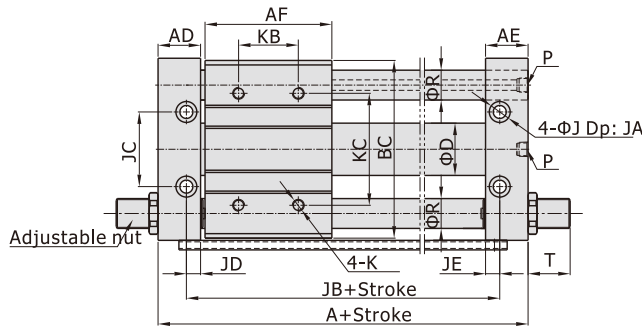

[Unit: mm]

Bore size/Item	A	AD	AE	AF	B	BC	C	CA	D	J	JA	JB	JC	JD	JE
16	107	22.5	22.5	60	75	72	40	39	18	9.5	5	75	30	6.5	6.5
20	124	25.5	25.5	70	90	87	46	45	22.8	9.5	5	90	38	8.5	8.5
25	124	25.5	25.5	70	100	97	54	53	27.8	11	6.5	90	42	8.5	8.5
32	148	28.5	28.5	85	122	119	66	64	35	14	8	110	50	9.5	9.5
40	170	35.5	35.5	95	145	142	76	74	43	14	8	120	64	10.5	10.5

Bore size/Item	K	KB	KC	L	LD	P	R	RB	S	T
16	M5×0.8Dp:10	30	50	M6×1.0Dp:9.5	5.5	M5×0.8	12	52	15.5	8.5
20	M6×1.0Dp:10	40	70	M6×1.0Dp:9.5	5.5	1/8"	16	63	22.5	10.5
25	M6×1.0Dp:10	40	70	M8×1.25Dp:10	7	1/8"	16	70	40.5	11.5
32	M8×1.25Dp:12	40	75	M10×1.5Dp:15	8.5	1/8"	20	86	57.5	17.5
40	M8×1.25Dp:12	65	105	M10×1.5Dp:15	8.5	1/4"	25	105	50.5	10.5