



# Compact cylinder—NACQ Series

## Compendium of NACQ Series

**In accordance with JIS standard**

**Magnetic switch slots around the cylinder body**

There are magnetic switch slots around the cylinder body convenient to install inducting switch.

**Two kinds of rod type**

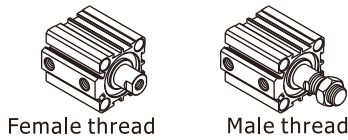

Female thread

Male thread

**Multi-mounting accessories**

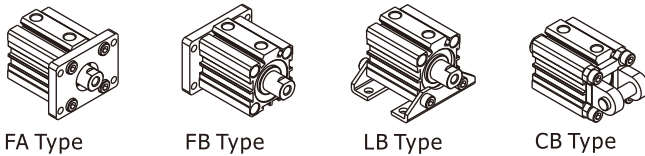

FA Type

FB Type

LB Type

CB Type

**Ten bore size are available**

Bore size: 12\16\20\25\32\40\50\63\80\100mm

**Multi-type cylinder**

NACQ: Compact cylinder (Double acting)



NASQ: Compact cylinder (Single acting-push)



NATQ: Compact cylinder (Single acting-pull)



NACQD: Compact cylinder (Double rod)

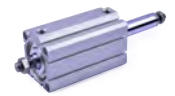

**Compact structure**

C clip is adopted to connect the cylinder body and back cover or front cover, and riveted structure is adopted to connect piston and piston rod to make it compact and reliable.

**Convenient and fast fix sensor switch**

Sensor can be directly fixed onto the groove of the cylinder, which is convenient and fast. the counterpart sensor type is: CMSH、DMSH、EMSH

## Installation and application



1. When load changes in the work, the cylinder with abundant output capacity shall be selected.
2. Relative cylinder with high temperature resistance or corrosion resistance shall be chosen under the condition of high temperature or corrosion.
3. Necessary protection measure shall be taken in the environment with higher humidity, much dust or water drops, oil dust and welding dregs.
4. Dirty substances in the pipe must be eliminated before cylinder is connected with pipeline to prevent the entrance of particles into the cylinder.
5. The medium used by cylinder shall be filtered to 40µm or below.
6. As both of the front cover and piston of the cylinder are short, typically too large stroke can not be selected.
7. Anti-freezing measure shall be adopted under low temperature environment to prevent moisture freezing.
8. The cylinder shall avoid the influence of side load in operation to maintain the normal work of cylinder and extend the service life.
9. If the cylinder is dismantled and stored for a long time, please conduct anti-rust treatment to the surface. Anti-dust caps shall be added in air inlet and outlet ports. The front and back cover can not be dismantled, which shall be especially noticed.
10. C clip Installation:
  - 10.1. Removal & Installation of C clip must be done with proper tool & care.
  - 10.2. Ensure C clip is securely fitted into the proper slot to prevent leakage.



## NACQ Series



### Ordering code

**NACQ 32X30 S B □ T**

① ② ③ ④ ⑤ ⑥ ⑦

① Model	② Bore size	③ Stroke	④ Magnet	⑤ Rod type	⑥ Mounting type[Note1]	⑦ Thread type
NACQ: Compact cylinder (Double acting)	12 16 20 25 32 40 50 63 80 100	Refer to stroke table for details	Blank: Without magnet S: With magnet	Blank: Female thread B: Male thread	Blank: No accessories FA: FA type FB: FB type CB: CB type LB: LB type	T: NPT [Note2]
NASQ: Compact cylinder (Single acting-push)	12 16 20 25 32 40 50					
NATQ: Compact cylinder (Single acting-pull)						
NACQD: Compact cylinder (Double rod)	12 16 20 25 32 40 50 63 80 100				Blank: No accessories FA: FA type FB: FB type LB: LB type	

[Note1] Please refer to page 316~318 for accessory parts.

[Note2]  $\Phi 12 \sim \Phi 25$  thread is #10-32UNF and is blank here.

### Stroke

Bore size (mm)		Standard stroke (mm)
12 16	Double acting	5 10 15 20 25 30
	Single acting	5 10
20 25	Double acting	5 10 15 20 25 30 35 40 45 50
	Single acting	5 10
32 40	Double acting	5 10 15 20 25 30 35 40 45 50 75 100
	Single acting	5 10
50	Double acting	10 15 20 25 30 35 40 45 50 75 100
	Single acting	10 20
63 80 100	Double acting	10 15 20 25 30 35 40 45 50 75 100

Note) 1. Please contact the company for other special strokes.

2. The dimensions of non-std stroke cylinder has the same dimensions as the next longer stroke std. stroke cylinder.

e.g. 23mm stroke cylinder has the same dimensions of 25 std. stroke cylinder.

### Specification

Bore size(mm)	12	16	20	25	32	40	50	63	80	100
Acting type	Double acting									
	Single acting_Push type, Single acting_Pull type								-	
Fluid	Air(to be filtered by 40 $\mu$ m filter element)									
Operating pressure	Double acting: 22~145psi(0.15~1.0MPa) Single acting: 28~145psi(0.2~1.0MPa)									
Proof pressure	215psi(1.5MPa)									
Temperature	-5°F~160°F(-20°C~70°C)									
Speed range mm/s	Double acting: 30~500					Single acting: 50~500				
Stroke tolerance mm						$\begin{matrix} +1.0 \\ 0 \end{matrix}$				
Cushion type	Bumper									
Port size	#10-32UNF				NPT1/8		NPT1/4		NPT3/8	

Add) Refer to P535 for detail of sensor switch.

## NACQ Series

### Product feature

1. JIS standard is implemented.
2. C clip is adopted to connect the cylinder body and back cover or front cover, and riveted structure is adopted to connect piston and piston rod to make it compact and reliable.
3. The internal diameter of the body is treated with rolling followed by the treatment of hard anodizing, forming an excellent abrasion resistance and durability.
4. The seal of piston adopts heterogeneous two-way seal structure. It has compact dimension and the function of grease reservation.
5. Compact structure can effectively save installation space.
6. There are magnetic switch slots around the cylinder body, which is convenient to install inducting switch.
7. Installing accessories with various specifications are optional.

### Criteria for selection: Cylinder thrust

Unit: Newton(N)

Bore size(mm)	Rod size(mm)	Acting type		Pressure area(mm <sup>2</sup> )	Operating pressure(psi)						
					15	30	45	60	75	90	105
12	6	Single acting	Push side	113.1	-	13.6	24.9	36.2	47.5	58.9	70.2
			Pull side	84.8	-	8.0	16.4	24.9	33.4	41.9	50.4
		Double acting	Push side	113.1	11.3	22.6	33.9	45.2	56.5	67.9	79.2
			Pull side	84.8	8.5	17.0	25.4	33.9	42.4	50.9	59.4
16	8	Single acting	Push side	201.1	-	27.0	47.1	67.2	87.3	107.4	127.5
			Pull side	150.8	-	17.0	32.0	47.1	62.2	77.3	92.4
		Double acting	Push side	201.1	20.1	40.2	60.3	80.4	100.5	120.6	140.7
			Pull side	150.8	15.1	30.2	45.2	60.3	75.4	90.5	105.6
20	10	Single acting	Push side	314.2	-	36.8	68.2	99.7	131.1	162.5	193.9
			Pull side	235.6	-	21.1	44.7	68.2	91.8	115.4	138.9
		Double acting	Push side	314.2	31.4	62.8	94.2	125.7	157.1	188.5	219.9
			Pull side	235.6	23.6	47.1	70.7	94.2	117.8	141.4	164.9
25	12	Single acting	Push side	490.9	18.1	67.2	116.3	165.3	214.4	263.5	312.6
			Pull side	377.8	6.8	44.6	82.3	120.1	157.9	195.7	233.4
		Double acting	Push side	490.9	49.1	98.2	147.3	196.3	245.4	294.5	343.6
			Pull side	377.8	37.8	75.6	113.3	151.1	188.9	226.7	264.4
32	16	Single acting	Push side	804.2	27.4	107.8	188.3	268.7	349.1	429.5	510.0
			Pull side	603.2	7.3	67.6	128.0	188.3	248.6	308.9	369.2
		Double acting	Push side	804.2	80.4	160.8	241.3	321.7	402.1	482.5	563.0
			Pull side	603.2	60.3	120.6	181.0	241.3	301.6	361.9	422.2
40	16	Single acting	Push side	1256.6	44.7	170.3	296.0	421.7	547.3	673.0	798.6
			Pull side	1055.6	24.6	130.1	235.7	341.2	446.8	552.3	657.9
		Double acting	Push side	1256.6	125.7	251.3	377.0	502.7	628.3	754.0	879.6
			Pull side	1055.6	105.6	211.1	316.7	422.2	527.8	633.3	738.9
50	20	Single acting	Push side	1963.5	96.3	292.7	489.0	685.4	881.7	1078.1	1274.4
			Pull side	1649.3	64.9	229.9	394.8	559.7	724.7	889.6	1054.5
		Double acting	Push side	1963.5	196.3	392.7	589.0	785.4	981.7	1178.1	1374.4
			Pull side	1649.3	164.9	329.9	494.8	659.7	824.7	989.6	1154.5
63	20	Double acting	Push side	3117.2	311.7	623.4	935.2	1246.9	1558.6	1870.3	2182.1
			Pull side	2803.1	280.3	560.6	840.9	1121.2	1401.5	1681.9	1962.2
80	25	Double acting	Push side	5026.5	502.7	1005.3	1508.0	2010.6	2513.3	3015.9	3518.6
			Pull side	4535.7	453.6	907.1	1360.7	1814.3	2267.8	2721.4	3175.0
100	32	Double acting	Push side	7854.0	785.4	1570.8	2356.2	3141.6	3927.0	4712.4	5497.8
			Pull side	7049.7	705.0	1409.9	2114.9	2819.9	3524.9	4229.8	4934.8

# Compact cylinder

## NACQ Series

### Inner structure

**NACQ**

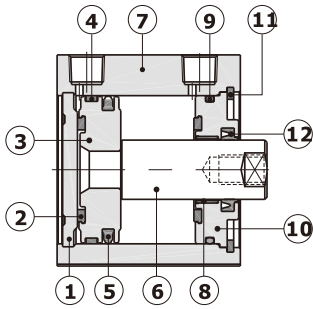

**NACQ-S**

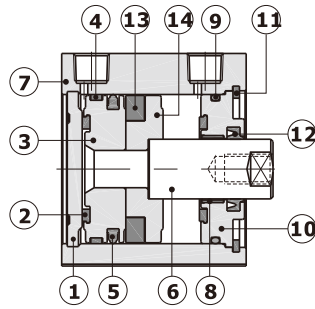

NO.	Item	NO.	Item
1	Back cover	8	Bushing
2	Bumper	9	O-ring
3	Piston	10	Front cover
4	Wear ring	11	C clip
5	Piston seal	12	Front cover packing
6	Piston rod	13	Magnet
7	Body	14	Magnet holder

### Dimensions

**NACQ**

Φ12, Φ16

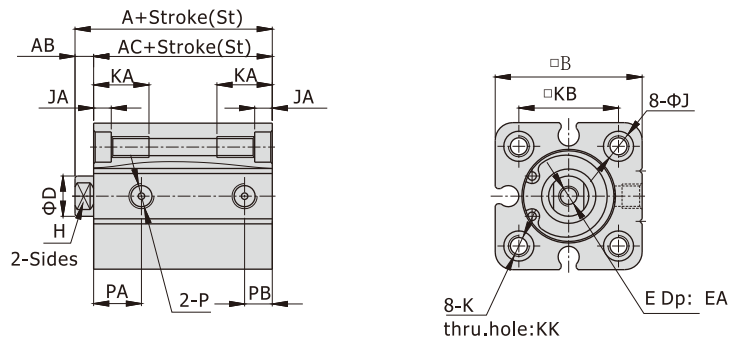

Φ20, Φ25

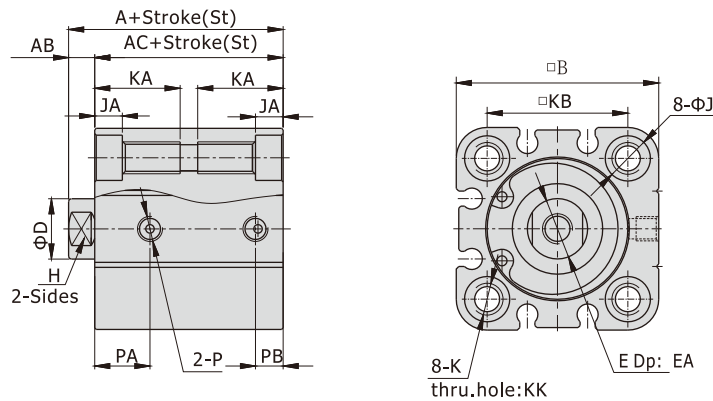

[Unit: mm]

Type	Without magnet		With magnet		AB	B	D	EA	J	JA	KK	KA	KB	PA	PB
	A	AC	A	AC											
12	20.5	17	30.5	27	3.5	25	6	6	6	3.5	Φ3.4	11	15.5	7.5	5
16	22	18.5	32	28.5	3.5	29	8	6	6	3.5	Φ3.4	11	20	8	5.5
20	24	19.5	34	29.5	4.5	36	10	8	9	5.5	Φ5.2	17	25.5	9	5.5
25	27.5	22.5	37.5	32.5	5	40	12	10	9	5.5	Φ5.2	17	28	11	5.5

[Unit: Inch]

Bore size(mm)\Item	E	K	P	H
12	#8-32 UNC	#8-32 UNC	#10-32 UNF	3/16
16	#8-32 UNC	#8-32 UNC	#10-32 UNF	1/4
20	#10-32 UNF	1/4-20 UNC	#10-32 UNF	5/16
25	1/4-28 UNF	1/4-20 UNC	#10-32 UNF	3/8

# Compact cylinder

## NACQ Series

Φ32~Φ100 (Stroke≤100)

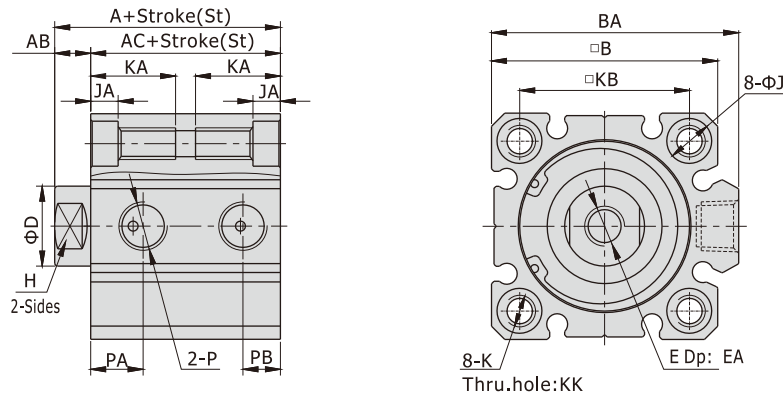

[Unit: mm]

Item	A(Without magnet)		A (With magnet)	AB	AC(Without magnet)		AC (With magnet)	B	BA	D	EA	J	JA	KK	KA	KB
	St≤50	St≥75			St≤50	St≥75										
32	30	40	40	7	23	33	33	45	49.5	16	13	9	5.5	Φ5.2	17	34
40	36.5	46.5	46.5	7	29.5	39.5	39.5	53	57	16	15	9	5.5	Φ5.2	17	40
50	38.5	48.5	48.5	8	30.5	40.5	40.5	64	71	20	18	10.5	6.5	Φ6.7	22.5	50
63	44	54	54	8	36	46	46	77	84	20	18	14	9	Φ8.5	28.5	60
80	53.5	63.5	63.5	10	43.5	53.5	53.5	98	104	25	20	17	11	Φ10.4	35.5	77
100	65	75	75	12	53	63	63	117	123.5	32	26	17	11	Φ10.4	35.5	94

[Unit: Inch]

Item	Without magnet		With magnet	
	PA	PB	PA	PB
32	St=5	7.5	10.5	7.5
	St>5	10.5		
40	11	8	11	8
50	10.5	10.5	10.5	10.5
63	15	10.5	15	10.5
80	16	14	16	14
100	20	17.5	20	17.5

Item	E	K	P	H
32	5/16-24 UNF	1/4-20 UNC	NPT1/8	9/16
40	3/8-24 UNF	1/4-20 UNC	NPT1/8	9/16
50	1/2-20 UNF	5/16-18 UNC	NPT1/4	11/16
63	1/2-20 UNF	7/16-14 UNC	NPT1/4	11/16
80	5/8-18 UNF	1/2-13 UNC	NPT3/8	7/8
100	3/4-16 UNF	1/2-13 UNC	NPT3/8	1-1/16

Note) The dimensions of non-std stroke cylinder has the same dimensions as the next longer stroke std. stroke cylinder.

e.g. 55mm stroke cylinder has the same dimensions of 60 std. stroke cylinder.

### Male thread

(Bore size: Φ12~Φ100, Stroke≤100)

[Unit: mm]

[Unit: Inch]

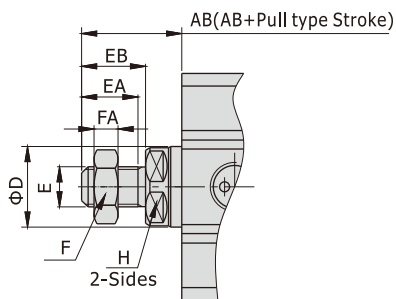

Bore size\Item	AB	D	EA	EB
12	11.5	6	6.5	7.5
16	11.5	8	6.5	7.5
20	12.5	10	6.5	7.5
25	14.5	12	7.5	9
32	19.5	16	12	13
40	23	16	14	16
50	27.5	20	19	20
63	27.5	20	19	20
80	35.5	25	25	26
100	40.5	32	27.5	29

Item	E	F	FA	H
12	#8-32 UNC	11/32	0.13	3/16
16	#8-32 UNC	11/32	0.13	1/4
20	#10-32 UNF	3/8	0.13	5/16
25	1/4-28 UNF	7/16	0.16	3/8
32	5/16-24 UNF	1/2	0.19	9/16
40	3/8-24 UNF	9/16	0.22	9/16
50	1/2-20 UNF	3/4	0.31	11/16
63	1/2-20 UNF	3/4	0.31	11/16
80	5/8-18 UNF	15/16	0.38	7/8
100	3/4-16 UNF	1-1/8	0.42	1-1/16

# Compact cylinder

## NACQ Series

### NASQ NATQ

Φ12, Φ16

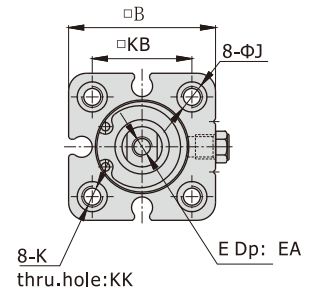
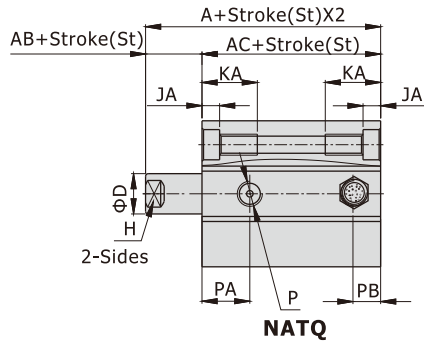
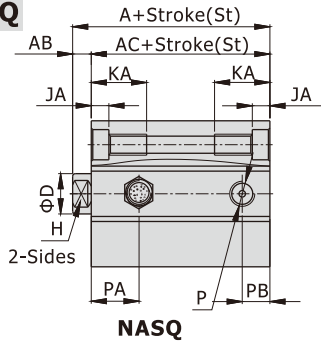

Φ20, Φ25

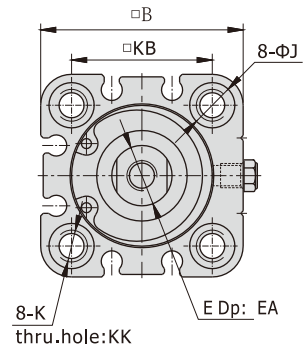
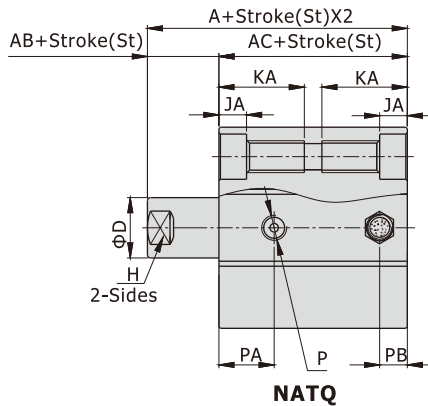
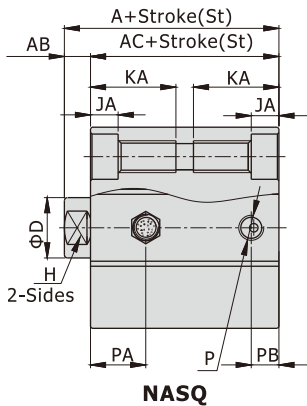

Φ32~Φ50

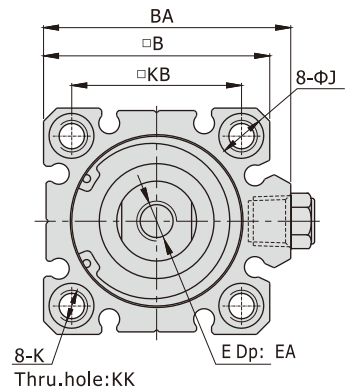
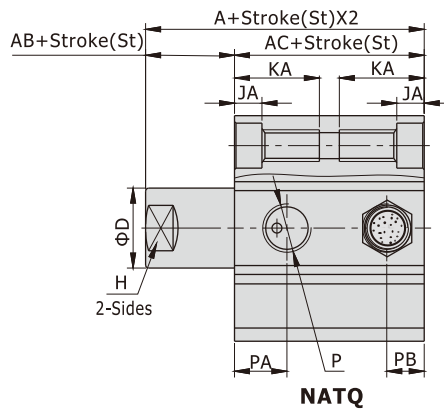
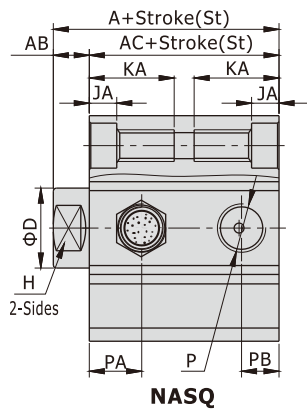

[Unit: mm]

Stroke	A(Without magnet)			A(With magnet)			AB	AC(Without magnet)			AC(With magnet)			B	BA	D	EA	J	JA
	5	10	20	5	10	20		5	10	20	5	10	20						
12	25.5	25.5	-	35.5	35.5	-	3.5	22	22	-	32	32	-	25	-	6	6	6	3.5
16	27	27	-	37	37	-	3.5	23.5	23.5	-	33.5	33.5	-	29	-	8	6	6	3.5
20	29	29	-	39	39	-	4.5	24.5	24.5	-	34.5	34.5	-	36	-	10	8	9	5.5
25	32.5	32.5	-	42.5	42.5	-	5	27.5	27.5	-	37.5	37.5	-	40	-	12	10	9	5.5
32	35	35	-	45	45	-	7	28	28	-	38	38	-	45	49.5	16	13	9	5.5
40	41.5	41.5	-	51.5	51.5	-	7	34.5	34.5	-	44.5	44.5	-	53	57	16	15	9	5.5
50	-	48.5	53.5	-	58.5	63.5	8	-	40.5	45.5	50.5	50.5	55.5	64	71	20	18	10.5	6.5

Bore size\Item	KK	KA	KB	PA	PB
12	Φ3.4	11	15.5	7.5	5
16	Φ3.4	11	20	8	5.5
20	Φ5.2	17	25.5	9	5.5
25	Φ5.2	17	28	11	5.5
32	Φ5.2	17	34	10.5	7.5
40	Φ5.2	17	40	11	8
50	Φ6.6	22.5	50	10.5	10.5

[Unit: Inch]

Bore size(mm)\Item	E	K	P	H
12	#8-32 UNC	#8-32 UNC	#10-32 UNF	3/16
16	#8-32 UNC	#8-32 UNC	#10-32 UNF	1/4
20	#10-32 UNF	1/4-20 UNC	#10-32 UNF	5/16
25	1/4-28 UNF	1/4-20 UNC	#10-32 UNF	3/8
32	5/16-24 UNF	1/4-20 UNC	NPT1/8	9/16
40	3/8-24 UNF	1/4-20 UNC	NPT1/8	9/16
50	1/2-20 UNF	5/16-18 UNC	NPT1/4	11/16



# Compact cylinder

## NACQ Series

### NACQD

Φ12, Φ16

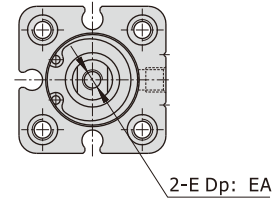
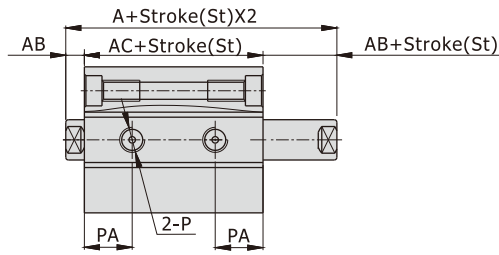

Φ20, Φ25

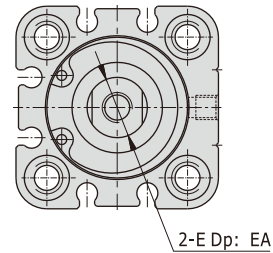
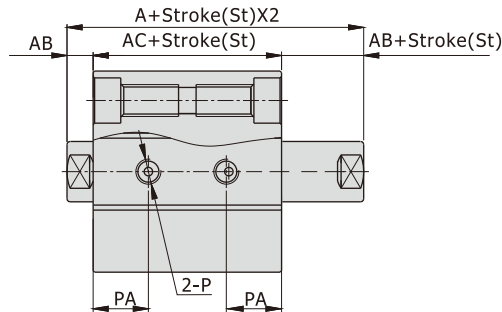

Φ32~Φ100

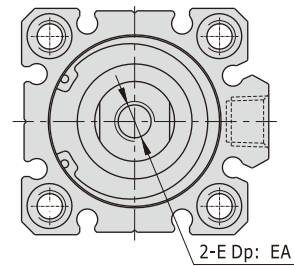
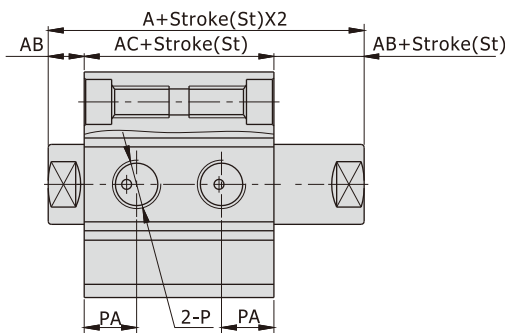

[Unit: mm]

[Unit: Inch]

Item Bore size	Without magnet		With magnet		AB	AF	EA	PA
	A	AC	A	AC				
12	32.2	25.2	42.2	35.2	3.5	17	6	9
16	33	26	43	36	3.5	21	6	9.5
20	35	26	45	36	4.5	25	8	9.5
25	39	29	49	39	5	27	9.5(St=5)/10(St>5)	11
32	44.5	30.5	54.5	40.5	7	28	9(St≤10)/13(St>10)	10
40	54	40	64	50	7	28	11(St≤10)/15(St>10)	13
50	56.5	40.5	66.5	50.5	8	29	12(St≤10)/18(St>10)	13.5
63	58	42	68	52	8	29	12(St≤10)/18(St>10)	16
80	71	51	81	61	10	35.5	14(St≤15)/20(St>15)	16
100	84.5	60.5	94.5	70.5	12	42.5	20(St=20)/26(St>20)	21

Item Bore size(mm)	E
12	#8-32 UNC
16	#8-32 UNC
20	#10-32 UNF
25	1/4-28 UNF
32	5/16-24 UNF
40	3/8-24 UNF
50	1/2-20 UNF
63	1/2-20 UNF
80	5/8-18 UNF
100	3/4-16 UNF

Remark) The unmarked dimension is the same as NACQ standard type.

## NACQ Series—Accessories

### List for ordering code of accessories

Accessories Bore size	Mounting accessories			Knuckle		Sensor switch
	LB	FA/FB	CB	I	Y	
12	F-NACQ12LB	F-NACQ12FA	F-NACQ12CB	F-NACQ12I	F-NACQ12Y	CM SH DM SH EM SH
16	F-NACQ16LB	F-NACQ16FA	F-NACQ16CB	F-NACQ16I	F-NACQ16Y	
20	F-NACQ20LB	F-NACQ20FA	F-NACQ20CB	F-NACQ20I	F-NACQ20Y	
25	F-NACQ25LB	F-NACQ25FA	F-NACQ25CB	F-NACQ25I	F-NACQ25Y	
32	F-NACQ32LB	F-NACQ32FA	F-NACQ32CB	F-NACQ32I	F-NACQ32Y	CM SH DM SH EM SH
40	F-NACQ40LB	F-NACQ40FA	F-NACQ40CB	F-NACQ40I	F-NACQ40Y	
50	F-NACQ50LB	F-NACQ50FA	F-NACQ50CB	F-NACQ50I	F-NACQ50Y	
63	F-NACQ63LB	F-NACQ63FA	F-NACQ63CB			
80	F-NACQ80LB	F-NACQ80FA	F-NACQ80CB	F-NACQ80I	F-NACQ80Y	
100	F-NACQ100LB	F-NACQ100FA	F-NACQ100CB	F-NACQ100I	F-NACQ100Y	

### Accessory selection

Cylinder model \ Accessories			Mounting accessories				Knuckle		Sensor switch		
			LB	FA	FB	CB [1]	I	Y	CM SH	DM SH	EM SH
NACQ	Female thread	Without magnet					x	x	x	x	x
		With magnet	•	•	•	•			•	•	•
	Male thread	Without magnet					•	•	x	x	x
		With magnet							•	•	•
NASQ NATQ	Female thread	Without magnet					x	x	x	x	x
		With magnet	•	•	•	•			•	•	•
	Male thread	Without magnet					•	•	x	x	x
		With magnet							•	•	•
NACQD	Female thread	Without magnet					x	x	x	x	x
		With magnet	•	•	x	x			•	•	•
	Male thread	Without magnet					•	•	x	x	x
		With magnet							•	•	•

[Note1] CB is attached with relevant PIN.

### Material of accessories

Accessories Bore size(mm)	Mounting accessories				Knuckle	
	LB	FA	FB	CB	I	Y
12, 15	■	•	•	•	■	■
20, 25	■	•	•	•	■	■
32~100	■	•	•	■	■	■

•—Aluminum alloy, ■—Steel

## NACQ Series—Accessories

### Dimensions

#### FA/FB

Φ12~Φ25

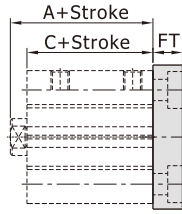
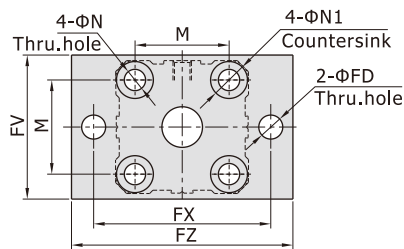

Φ32~Φ100

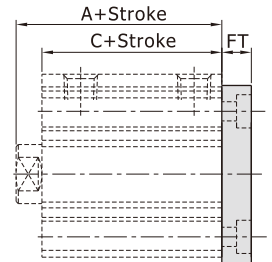
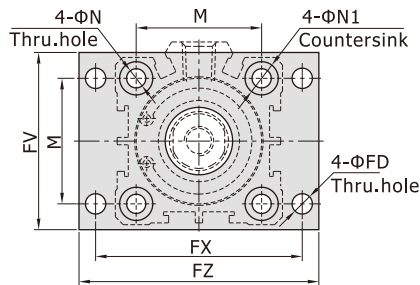

[Unit: mm]

Item Bore size Stroke	A [Note1]			C			M	N	N1	FD	FT	FV	FX	FZ
	Without magnet		With magnet	Without magnet		With magnet								
	≤50	≥75		≤50	≥75									
12	20.5	-	30.5	17	-	27	15.5	4.6	7.5	4.6	5.5	25	45	55
16	22	-	32	18.5	-	28.5	20	4.6	7.5	4.6	5.5	30	45	55
20	24	-	34	19.5	-	29.5	25.5	6.8	10	6.8	8	39.5	48	60
25	27.5	-	37.5	22.5	-	32.5	28	6.8	10	6.8	8	42	52	64
32	30	40	40	23	33	33	34	6.8	10	5.5	8	48	56	65
40	36.5	46.5	46.5	29.5	39.5	39.5	40	6.8	10	5.5	8	54	62	72
50	38.5	48.5	48.5	30.5	40.5	40.5	50	8.5	11.5	6.8	9	67	76	89
63	44	54	54	36	46	46	60	11.6	16.5	9	10	80	92	108
80	53.5	63.5	63.5	43.5	53.5	53.5	77	13.2	19.5	11	12	99	116	134
100	65	75	75	53	63	63	94	13.2	19.5	11	12	117	136	154

[Note] Value A and C in the above table are only for NACQ series.  
Please refer to relevant content for value A and C of other series.

#### LB

Φ12~Φ25

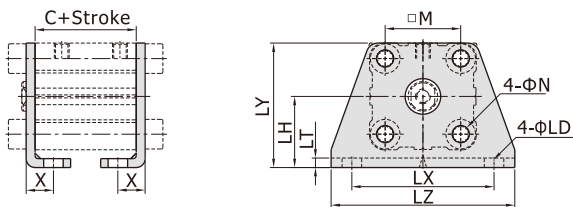

Φ32~Φ100

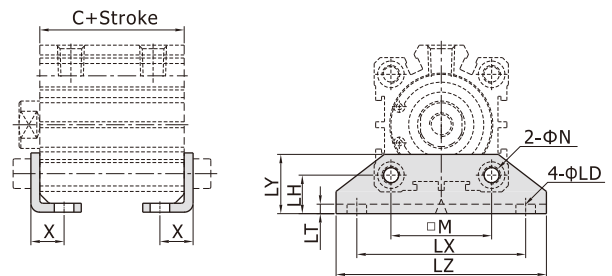

[Unit: mm]

Bore size/Item Stroke	C [Note]			M	N	X	LD	LH	LT	LX	LY	LZ
	Without magnet		With magnet									
	≤50	≥75										
12	17	-	27	15.5	4.6	8	4.6	17	2	34	29.5	44
16	18.5	-	28.5	20	4.6	8	4.6	19	2	38	33.5	48
20	19.5	-	29.5	25.5	6.8	9.2	6.8	24	3	48	42	62
25	22.5	-	32.5	28	6.8	10.7	6.8	26	3	52	46	66
32	23	33	33	34	6.8	11.2	6.8	13	3	57	20	71
40	29.5	39.5	39.5	40	6.8	11.2	6.8	13	3	64	20	78
50	30.5	40.5	40.5	50	8.5	12.2	8.5	14	3	79	22	95
63	36	46	46	60	11.6	13.7	11.6	16	3	95	26	113
80	43.5	53.5	53.5	77	13.5	16.5	13.5	20.5	4.5	118	32	140
100	53	63	63	94	13.5	23	13.5	24	6	137	36	162

[Note] Value C in the above table is only for NACQ series. Please refer to relevant content for value C of other series.

## NACQ Series—Accessories

### CB $\phi 12\sim\phi 25$

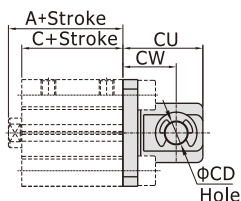
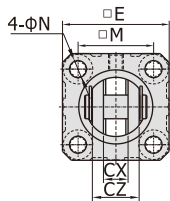

### $\phi 32\sim\phi 100$

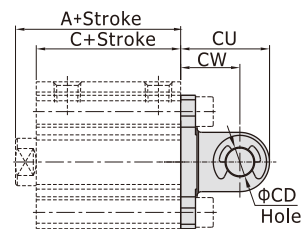
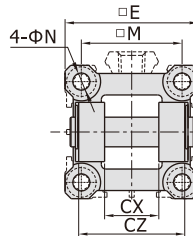

[Unit: mm]

Item Bore size Stroke	A [Note]			C			E	M	N	CD (inch)	CU	CW	CX	CZ
	Without magnet		With magnet	Without magnet		With magnet								
	≤50	≥75		≤50	≥75									
12	20.5	-	30.5	17	-	27	25	15.5	4.6	3/16	20	14	5.3	9.8
16	22	-	32	18.5	-	28.5	29	20	4.6	3/16	21	15	6.8	11.8
20	24	-	34	19.5	-	29.5	36	25.5	6.8	5/16	27	18	8.3	15.8
25	27.5	-	37.5	22.5	-	32.5	40	28	6.8	3/8	30	20	10.3	19.8
32	30	40	40	23	33	33	45.5	34	6.8	3/8	30	20	18.3	35.8
40	36.5	46.5	46.5	29.5	39.5	39.5	53.5	40	6.8	3/8	32	22	18.3	35.8
50	38.5	48.5	48.5	30.5	40.5	40.5	64.5	50	8.5	1/2	42	28	22.3	43.8
63	44	54	54	36	46	46	77.5	60	11.6	1/2	44	30	22.3	43.8
80	53.5	63.5	63.5	43.5	53.5	53.5	98.5	77	13.2	3/4	56	38	28.3	55.8
100	65	75	75	53	63	63	117.5	94	13.2	7/8	67	45	32.3	63.8

[Note] Value A and C in the above table are only for NACQ series.  
Please refer to relevant content for value A and C of other series.

### Y Knuckle

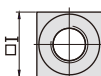

F-NACQ12Y  
F-NACQ16Y  
F-NACQ20Y  
F-NACQ25Y

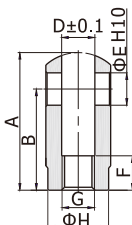
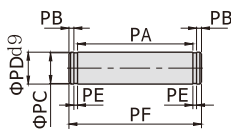

F-NACQ32Y  
F-NACQ40Y  
F-NACQ50Y  
F-NACQ80Y  
F-NACQ100Y

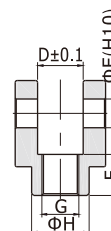
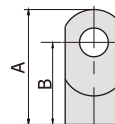
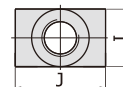

[Unit: mm]

Type\Item	A	B	D	E(inch)	F	G	H	I	J	PA	PB	PC	PD(inch)	PE	PF
F-NACQ12Y	22	16	5.3	3/16	6	#8-32UNC	9	10	-	10.2	1.5	4	3/16	0.7	14.6
F-NACQ16Y	28	21	6.6	3/16	11	#8-32UNC	11	12	-	12.4	1.5	4	3/16	0.7	16.8
F-NACQ20Y	34	25	8.3	5/16	8.5	#10-32UNF	15	16	-	16.2	1.5	7	5/16	0.9	21
F-NACQ25Y	41	30	10.3	3/8	10.5	1/4-28UNF	19	20	-	20.2	2	8	3/8	1.1	26.4
F-NACQ32Y	42	30	18.4	3/8	16	5/16-24UNF	22	22	36	36.2	2	8	3/8	1.1	42.4
F-NACQ40Y	42	30	18.4	3/8	16	3/8-24UNF	22	22	36	36.2	2	8	3/8	1.1	42.4
F-NACQ50Y	56	40	22.4	1/2	20	1/2-20UNF	28	28	44	44.2	2	12	1/2	1.1	50.4
F-NACQ80Y	71	50	28.4	3/4	23	5/8-18UNF	38	38	56	56.2	2	15	3/4	1.7	63.6
F-NACQ100Y	79	55	32.4	7/8	24	3/4-16UNF	44	44	64	64.2	2.5	19	7/8	1.7	72.6

[Unit: mm]

### I Knuckle

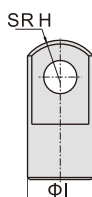
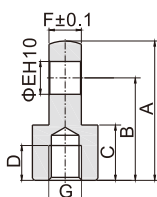

Type\Item	A	B	C	D	E(inch)	F	G	H	I
F-NACQ12I	21.5	16	9	6	3/16	4.7	#8-32UNC	6.3	10
F-NACQ16I	32	25	11	6	3/16	6.2	#8-32UNC	8.1	12
F-NACQ20I	34	25	13.5	6	5/16	7.7	#10-32UNF	10.3	16
F-NACQ25I	41	30	16	8	3/8	9.7	1/4-28UNF	12.8	20
F-NACQ32I	42	30	16	14	3/8	17.6	5/16-24UNF	12	22
F-NACQ40I	42	30	16	14	3/8	17.6	3/8-24UNF	12	22
F-NACQ50I	56	40	20	18	1/2	21.6	1/2-20UNF	16	28
F-NACQ80I	71	50	23	21	3/4	27.6	5/8-18UNF	21	38
F-NACQ100I	79	55	24	22	7/8	31.6	3/4-16UNF	24	44